

**SAMPLE QUESTION PAPER**  
**Summative Assessment – II**  
**Class-X (2016–17)**  
**Mathematics**

**Time Allowed: 3 Hours**

**Max. Marks: 90**

**General Instructions:**

1. All questions are compulsory.
2. The question paper consists of 31 questions divided into four sections A, B, C and D
3. Section A contains 4 questions of 1 mark each. Section B contains 6 questions of 2 marks each. Section C contains 10 questions of 3 marks each. Section D contains 11 questions of 4 marks each.
4. Use of calculators is not permitted.

**SECTION – A**

(Question numbers 1 to 4 carry 1 mark each)

1. A letter is chosen at random from the letter of the “word PROBABILITY”. Find the probability that it is a not a vowel.
2. Find the 17th term from the end of the AP: 1, 6, 11, 16..... 211, 216
3. A pole 6 m high casts a shadow  $2\sqrt{3}$  m long on the ground, then find the angle of elevation of the sun.
4. In the given figure PA and PB are tangents to a circle with centre O. If

$\angle APB = (2x + 3)^\circ$  and  $\angle AOB = (3x + 7)^\circ$ , then find the value of  $x$

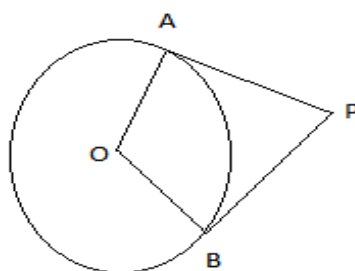

**SECTION – B**

(Question numbers 5 to 10 carry 2 marks each)

5. Find the sum of all natural numbers that are less than 100 and divisible by 4.
6. Find the value of  $p$  for which the points  $(-1, 3)$ ,  $(2, p)$  and  $(5, -1)$  are collinear.
7. Find the value(s) of  $k$ , for which the equation  $kx^2 - kx + 1 = 0$  has equal roots.

8. Using the figure given below, prove that  $AR = \frac{1}{2}$  (perimeter of triangle ABC)

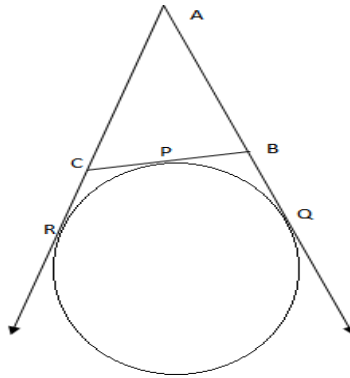

9. P and Q are the points with co-ordinates (2, -1) and (-3, 4). Find the co-ordinates of the point R such that PR is  $\frac{2}{5}$  of PQ.
10. In the given figure, common tangents AB and CD to the two circles intersect at E. Prove that  $AB = CD$ .

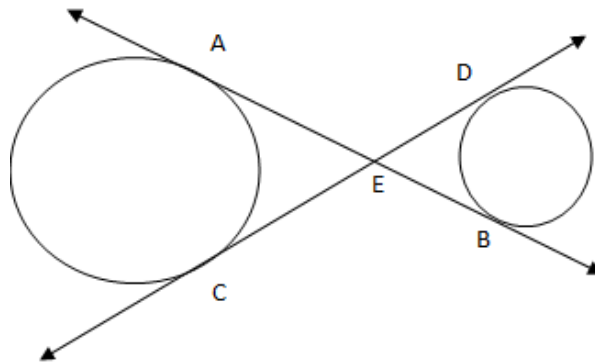

### SECTION – C

(Question numbers 11 to 20 carry 3 marks each)

11. Solve the given equation by the method of completing the squares:

$$x^2 + 12x - 45 = 0$$

12. The sum of first six terms of an A.P. is 42. The ratio of its 10<sup>th</sup> term to its 30<sup>th</sup> term is 1:3. Find the first term of the A.P.
13. From the top of a lighthouse 75 m high, the angles of depression of two ships are observed to be 30° and 45° respectively. If one ship is directly behind the other on the same side of the lighthouse then find the distance between the two ships.
14. The vertices of a triangle are A (-1, 3), B (1, -1) and C (5, 1). Find the length of the median through the vertex C.

15. The king, queen and jack of diamond are removed from a deck of 52 playing cards and then well shuffled. Now one card is drawn at random from the remaining cards. Determine the probability that the card drawn is :
- A face card.
  - A red card.
  - A king.
16. Find the area of the minor segment of a circle of radius 42cm, if the length of the corresponding arc is 44 cm.
17. A cylindrical pipe has inner diameter of 4 cm and water flows through it at the rate of 20 meter per minute. How long would it take to fill a conical tank of radius 40 cm and depth 72cm?
18. In given figure, PS is the diameter of a circle of radius 6 cm. The points Q and R trisects the diameter PS. Semi circles are drawn on PQ and QS as diameters. Find the area of the shaded region.

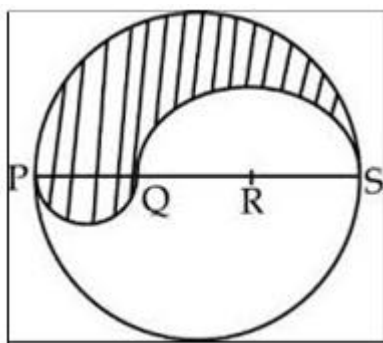

19. Find the number of spherical lead shots , each of diameter 6 cm that can be made from a solid cuboid of lead having dimensions 24 cm  $\times$  22 cm  $\times$  12 cm.
20. A wooden souvenir is made by scooping out a hemisphere from each end of a solid cylinder. If the height of the cylinder is 10 cm and its base is of radius 3.5 cm then find the total cost of polishing the souvenir at the rate of Rs. 10 per cm<sup>2</sup>.
- SECTION – D**
- (Question numbers 21 to 31 carry 4 marks each)
21. Draw a  $\Delta ABC$  with sides BC = 5cm, AB = 6cm and AC = 7cm and then construct a triangle similar to  $\Delta ABC$  whose sides are  $\frac{4}{7}$  of the corresponding sides of  $\Delta ABC$ .
22. A train covers a distance of 90 kms at a uniform speed. It would have taken 30 minutes less if the speed had been 15 km/hr more. Calculate the original duration of the journey

23. Cards marked with numbers 1, 3, 5... 49 are placed in a box and mixed thoroughly. One card is drawn from the box. Find the probability that the number on the card is
- divisible by 3
  - a composite number
  - Not a perfect square
  - Multiple of 3 and 5.

24. In given figure, XY and PQ are two parallel tangents to a circle with centre O and another tangent AB with point of contact C intersecting XY at A and PQ at B. Prove that  $\angle AOB = 90^\circ$

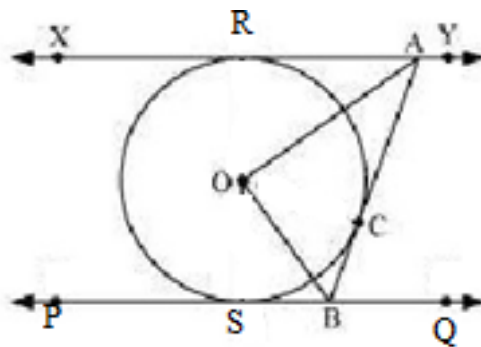

25. Solve the following quadratic equation by applying the quadratic formula:

$$p^2x^2 + (p^2 - q^2)x - q^2 = 0$$

26. The points A ( 1 , -2 ) , B ( 2 , 3 ) , C ( k , 2 ) and D ( - 4 , - 3 ) are the vertices of a parallelogram. Find the value of k and the altitude of the parallelogram corresponding to the base AB.
27. From a point 100 m above a lake the angle of elevation of a stationary helicopter is  $30^\circ$  and the angle of depression of reflection of the helicopter in the lake is  $60^\circ$ . Find the height of the helicopter above the lake.
28. A donor agency ensures milk is supplied in containers, which are in the form of a frustum of a cone to be distributed to flood victims in a camp. The height of each frustum is 30 cm and the radii of whose lower and upper circular ends are 20 cm and 40 cm respectively. . If this milk is available at the rate of Rs.35 per litre and 880 litres of milk is needed daily for a camp.
- Find how many milk containers are needed daily for the camp.
  - What daily cost will it put on the donor agency?
  - What value of the donor agency is depicted in this situation?

29. The radii of two concentric circles are 13 cm and 8 cm. AB is a diameter of the bigger circle and BD is tangent to the smaller circle touching it at D and intersecting the larger circle at P, on producing. Find the length of AP.
30. A manufacturer of TV sets produced 600 units in the 3rd year and 700 units in the 7th year. Assuming that, production increases uniformly by a fixed number of units every year. Find
- (i) The production in 1<sup>st</sup> year.
  - (ii) The production in 10<sup>th</sup> year.
  - (iii) The total production in 7 years.
31. 50 circular discs, each of radius 7cm and thickness 0.5cm are placed one above the other. Find the total surface area of the solid so formed. Find how much space will be left in a cubical box of side 25cm if the solid formed is placed inside it.

--000--

Buy the latest MTG CBSE books best prices at - <https://bit.ly/3QNnoOI>

**SAMPLE QUESTION PAPER**  
**MATHEMATICS**  
**CLASS-X (2016-17)**  
**SUMMATIVE ASSESSMENT -II**

**MARKING SCHEME**

**SECTION -A**

- |    |      |     |
|----|------|-----|
| 1. | 7/11 | [1] |
| 2. | 136  | [1] |
| 3. | 60°  | [1] |
| 4. | 34°  | [1] |

**SECTION-B**

- |    |  |  |
|----|--|--|
| 5. | Here $a=4$ , $d=4$ and $a_n= 96$<br>So, $a_n = a+ (n-1)d$<br>$96 = 4+(n-1)4$<br>$\therefore n=24$  | [1/2]<br><br><br><br>[1/2]                       |
|    | Now, $S_{24} = \frac{n}{2}(a+a_n)$   | [1/2]  |
|    | $\therefore S_{24} = 1200$   | [1/2]  |
| 6. | Let A( -1 , 3 ), B( 2 , p) and C( 5 , - 1 ) be 3 collinear points.<br>Then Area $\Delta ABC = 0$<br>Then, $\frac{1}{2} [-1(p+1)+2(-1-3)+5(3-p)]=0$<br>i.e. $-p-1-8+15-5p=0$<br>i.e. $6=6p$<br>i.e. $p=1$ | [1/2]<br><br><br>[1]<br><br><br>[1/2]            |
| 7. | For equal roots, $b^2-4ac=0$<br>Here, $a= k$ , $b= -k$ and $c=1$<br>$\therefore k^2- 4(k)(1)=0$<br>i.e. $k(k- 4)=0$<br>i.e. $k=0$ or $k= 4$<br>rejecting $k=0$ , we get $k= 4$ .                         | [1/2]<br><br><br>[1/2]<br><br><br>[1/2]<br>[1/2] |
| 8. | Perimeter of $\Delta ABC= AB+BC+CA$<br>$= AB+[ BP+CP]+CA$<br>$= AB+BQ+CR+CA$ (Tangents from an external point are equal)<br>$= AQ+AR$<br>$= AR+AR$ (Tangents from an external point are equal)<br>$=2AR$ | [1/2]<br>[1/2]<br>[1/2]<br><br>[1/2]             |

9. Point R divides PQ in ratio 2:3. [1/2]

Co-ordinates of point R are given by

$$x = (2 \times -3 + 3 \times 2)/5=0 \quad [1/2]$$

$$y = (2 \times 4 + 3 \times -1)/5=1 \quad [1/2]$$

So, the required point R is (0,1) [1/2]

10.

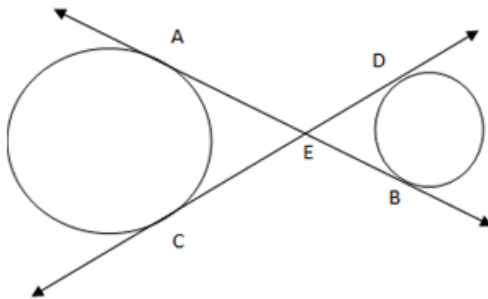

Tangents drawn to a circle from same external point are equal in length. So, [1/2]

$$AE = CE \quad \text{-----} \quad (1) \quad [1/2]$$

$$\text{And } EB = ED \quad \text{-----} \quad (2) \quad [1/2]$$

Adding (1) and (2) , we get,

$$AB = CD. \quad [1/2]$$

### SECTION – C

11.  $x^2 + 12x - 45 = 0$

Using the method of completing the square,

$$x^2 + 12x - 45 + 36 = 36 \quad [1/2]$$

$$\text{i.e. } x^2 + 12x + 36 = 36 + 45$$

$$\text{i.e. } (x+6)^2 = 81 \quad [1]$$

$$\text{i.e. } (x+6) = \pm 9 \quad [1/2]$$

$$\text{i.e. } x = 3 \text{ or } -15 \quad [1]$$

12.  $\frac{a+9d}{a+29d} = \frac{1}{3} \quad [1]$

$$\text{i.e. } 3a + 27d = a + 29d$$

i.e.  $a=d$ -----(1) [1/2]

Also,  $S_6 = 42$

i.e.  $\frac{6}{2}(2a+5d)=42$  [1]

i.e.  $3(2a+5a)=42$  Using... (1)

i.e.  $3(7a)=42$

i.e.  $a=2$  [1/2]

13. Let AB represent the lighthouse.  
 $\angle ACB=45^\circ$  and  $\angle ADB=30^\circ$

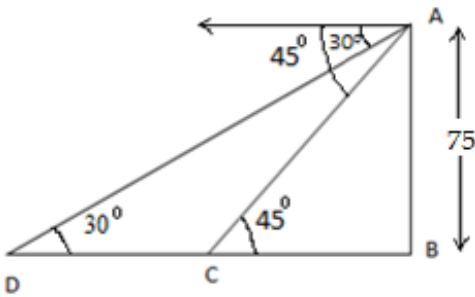

Fig [1]

In  $\triangle ABC$ ,  
 $\tan 45^\circ = AB/BC$   
 $1 = 75/BC$

i.e.  $BC=75m$  [1]

Now, in  $\triangle ABD$ ,  
 $\tan 30^\circ = AB/BD$

i.e.  $1/\sqrt{3} = 75/(BC+CD)$

i.e.  $1/\sqrt{3} = 75/(75 + CD)$

i.e.  $75 + CD = 75\sqrt{3}$

i.e.  $CD = 75(\sqrt{3} - 1) m$  [1]

14. Let  $A(-1,3)$ ,  $B(1,-1)$  and  $C(5,1)$  be the vertices of  $\triangle ABC$ .

Median through C would be the line joining C and midpoint of side AB. Let it be point D

$$D = \left( \frac{-1+1}{2}, \frac{3-1}{2} \right)$$
 [1]

Coordinates of D are  $(0,1)$  [1/2]

Length of median  $CD = \sqrt{(5-0)^2 + (1-1)^2}$  [1]

$= 5$  units. [1/2]

15. No. of cards left =  $52-3=49$

$P(\text{face card}) = \frac{9}{49}$  [1]

$P(\text{red card}) = \frac{23}{49}$  [1]

$P(\text{a king}) = \frac{3}{49}$  [1]



$$16. \frac{\theta}{360} \times 2\pi r = 44. \quad [1/2]$$

Putting  $r=42\text{cm}$ , we get  $\theta=60^\circ$  [1]

Now, Area of minor segment = Area of minor sector - Area of  $\Delta$

Since  $\theta=60^\circ$ , so the triangle formed will be an equilateral  $\Delta$

$\therefore$  Area of minor segment = Area of minor sector - Area of equilateral  $\Delta$

$$\text{i.e. Area of minor segment} = \frac{\theta}{360} \times \pi r^2 - \frac{\sqrt{3}}{4} a^2 \quad [1]$$

$$= 924 - 441\sqrt{3} \text{ cm}^2 \quad [1/2]$$

17. Time required to fill the conical vessel = Volume of cone / volume of water coming out of cylindrical pipe per unit time [1/2]

$$= \frac{\frac{1}{3} \pi r_1^2 h_1}{\pi r_2^2 h_2} \quad [1]$$

$$= [1/3 \pi (40)^2 \times 72] / \pi (2)^2 \times 20 \times 100 \quad [1]$$

$$= 4.8 \text{ minutes} \quad [1/2]$$

18. Area of shaded region = Area of semicircle with diameter PS - Area of semicircle with diameter QS + Area of semicircle with diameter PQ. [1]

$$\text{So, required area} = \frac{1}{2} \pi (6)^2 - \frac{1}{2} \pi (4)^2 + \frac{1}{2} \pi (2)^2 \quad [1]$$

$$= \frac{1}{2} \pi [36 - 16 + 4] \text{ cm}^2 \quad [1/2]$$

$$= 37.71 \text{ cm}^2 \quad [1/2]$$

$$19. \text{ No. of lead shots} = \frac{\text{Volume of cuboid}}{\text{Volume of sphere}} \quad [1/2]$$

$$= \frac{l_1 b_1 h_1}{\frac{4}{3} \pi r_2^3} \quad [1]$$

$$= \frac{24 \times 22 \times 12 \times 3}{\pi \times 3 \times 3 \times 3 \times 4} \quad [1]$$

$$= 56 \quad [1/2]$$

$$20. \text{ Required surface area} = 2 \pi r h + 2 \times [2 \pi r^2] \quad [1/2 + 1/2]$$

$$= 2 \times \pi \times 3.5 \times 10 + 4 \pi (3.5)^2 \quad [1]$$

$$= 374 \text{ cm}^2 \quad [1/2]$$

$$\text{Cost of polishing} = \text{Rs.} 374 \times 10 = \text{Rs.} 3740 \quad [1/2]$$

### SECTION -D

21. Correct Construction of  $\Delta ABC$  [2]

Correct construction of similar triangle [2]

22. Let the speed of the train be  $x$  km/hr.

According to question,

$$\frac{90}{x} - \frac{90}{x+15} = \frac{1}{2} \quad [1]$$

$$\text{i.e. } x^2 + 15x - 2700 = 0 \quad [1]$$

Solving for x we get,

$$x = -60 \text{ or } 45 \quad [1]$$

Rejecting  $x = -60$ , we get,  $x = 45$

So,  $x = 45$  km/hr [1/2]

Time = Distance / Speed

$$= \frac{90}{45} = 2 \text{ hours} \quad [1/2]$$

23. (i) Cards marked with numbers which are multiples of 3 are 3, 9, 15, 21, 27, 33, 39 and 45.

$$\text{So, } P(\text{getting a number divisible by 3}) = \frac{8}{25} \quad [1]$$

$$\text{(ii) } P(\text{composite number}) = \frac{10}{25} \quad [1]$$

$$\text{(iii) } P(\text{not a perfect square}) = 1 - P(\text{perfect square}) = 1 - \frac{4}{25} = \frac{21}{25} \quad [1]$$

$$\text{(iv) } P(\text{multiple of 3 and 5}) = \frac{2}{25} \quad [1]$$

24.

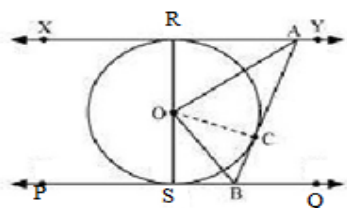

Construction: Join OR, OC and OS. [1/2]

In  $\triangle OAR$  and  $\triangle OCA$

$$OR = OC \text{ (radii)}$$

$AO = AO$  (common)

$AR = AC$  (tangents from an external point)

$$\triangle OAR \cong \triangle OCA \text{ (By SSS rule)} \quad [1]$$

$$\therefore \angle RAO = \angle CAO \text{ (CPCT)} \dots\dots\dots (1) \quad [1/2]$$

Similarly  $\triangle OSB \cong \triangle OCB$  (By SSS rule)

$$\therefore \angle SBO = \angle CBO \text{ (CPCT)} \dots\dots\dots (2) \quad [1/2]$$

$$\angle RAB + \angle SBA = 180^\circ \text{ (Co- interior angles)}$$

$$2\angle OAB + 2\angle OBA = 180^\circ \text{ (From (1) \& (2))}$$

$$\angle OAB + \angle OBA = 90^\circ \dots\dots\dots (3) \quad [1]$$

In  $\triangle AOB$ ,

$$\angle OAB + \angle OBA + \angle AOB = 180^\circ \text{ (Angle sum property)}$$

$$90^\circ + \angle AOB = 180^\circ \text{ (From 3)}$$

$$\angle AOB = 90^\circ \quad [1/2]$$

25. Quadratic formula,  $x = \frac{-b \pm \sqrt{b^2 - 4ac}}{2a}$  [1]  
 $a = p^2, b = (p^2 - q^2), c = -q^2$  [1/2]  
 $x = \frac{- (p^2 - q^2) \pm \sqrt{(p^2 - q^2)^2 - 4p^2 (-q^2)}}{2p^2}$  [1]  
 $x = \frac{-p^2 + q^2 \pm (p^2 + q^2)}{2p^2}$  [1/2]  
 $x = q^2/p^2$  or  $-1$  [1]

26. Diagonals of a parallelogram bisect each other,  
 So, midpoint of AC = midpoint of BD [1/2]  
 i.e.  $(\frac{1+k}{2}, \frac{2-2}{2}) = (\frac{2-4}{2}, \frac{3-3}{2})$  [1/2]  
 i.e.  $\frac{(1+k)}{2} = -1$   
 i.e.  $k = -3$  [1/2]  
 Now ar ABCD = 2 Area of  $\Delta ABD$   
 $= 2 \times \frac{1}{2} \times [1(6) + 2(-1) - 4(-5)]$   
 $= 24$  sq units. [1]

$AB = \sqrt{(1-2)^2 + (-2-3)^2}$   
 $= \sqrt{26}$  units [1/2]

Ar (ABCD) = base x height  
 $= AB \times h$

So,  $24 = \sqrt{26} \times h$

So,  $h = 24/\sqrt{26}$  units [1]

27.

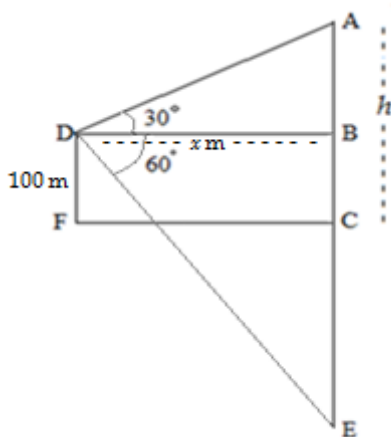

Let FC be the lake and D be a point 100m above the lake.

Let A be the helicopter at height  $h$  metre above the lake and let E be its reflection  $\therefore CE = h$  metre

$\angle BDE = 60^\circ, \angle ADB = 30^\circ$  and  $DB = x$  metre [1 mark for correct figure and description]

$\tan 30^\circ = \frac{h-100}{x}$

$1/\sqrt{3} = \frac{h-100}{x}$

$$h = x/\sqrt{3} + 100 \text{ ----- (1)} \quad [1]$$

$$\text{Tan } 60^\circ = \frac{h+100}{x}$$

$$\sqrt{3} x = h+100$$

$$h = \sqrt{3}x - 100 \text{ ----- (2)} \quad [1]$$

From equation 1 & 2

$$x/\sqrt{3} + 100 = \sqrt{3}x - 100$$

$$x = 100\sqrt{3}\text{m}$$

and so  $h=200\text{m}$  [1]

i.e. height of the helicopter is 200m.

28. (i) Volume of each container =  $\frac{1}{3}\pi h(r_1^2 + r_2^2 + r_1r_2)$  [1/2]

$$= \frac{1}{3} \times \frac{22}{7} \times 30(20^2 + 40^2 + 20 \times 40)$$

$$= 88000\text{cm}^3 = 88 \text{ l} \quad [1]$$

Total milk = 880 l

a) Milk in 1 container = 88 l

So number of containers =  $\frac{880}{88} = 10$  [1]

b) Cost =  $880 \times 35 = \text{Rs.}30800$  [1/2]

c) Any relevant Value inculcated [1]

29.

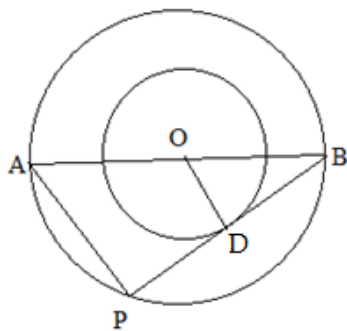

[Correct Figure 1 mark]

$\angle APB = 90^\circ$  (angle in a semicircle)

$\angle ODB = 90^\circ$  (tangent is perpendicular to the radius)

$\triangle APB$  and  $\triangle ODB$

$\angle APB = \angle ODB = 90^\circ$  [1/2]

$\angle ABP = \angle OBD$  (common) [1/2]

$\triangle APB \sim \triangle ODB$  (AA) [1/2]

$$\therefore \frac{OD}{AP} = \frac{OB}{AB} \text{ (CPST)} \quad [1/2]$$

$$\frac{8}{AP} = \frac{13}{26} \quad [1/2]$$

$$AP = 16\text{cm} \quad [1/2]$$

$$30. \text{ (i) } a_3 = 600 \quad \therefore a + 2d = 600 \text{ ----- (1)} \quad [1/2]$$

$$a_7 = 700 \quad \therefore a + 6d = 700 \text{ -----(2)} \quad [1/2]$$

From (1) & (2)

$$d = 25, a = 550$$

$$\text{(i) } a_1 = 550 \quad [1]$$

$$\text{(ii) } a_{10} = a + 9d = 550 + 9 \times 25 = 775 \quad [1]$$

$$\begin{aligned} \text{(iii) } S_7 &= \frac{7}{2}(2 \times 550 + 6 \times 25) \\ &= 4375 \end{aligned} \quad [1]$$

$$31. r = 7\text{cm}, h = 50 \times 0.5 = 25\text{cm} \quad [1/2]$$

$$\text{Total Surface Area} = 2\pi r(r + h) \quad [1/2]$$

$$= 2 \times \frac{22}{7} \times 7 \times (7 + 25)$$

$$= 1408 \text{ cm}^2 \quad [1]$$

$$\text{Volume of the box} = 25 \times 25 \times 25 = 15625 \text{ cm}^3 \quad [1/2]$$

$$\text{Volume of the solid formed} = \pi r^2 h \quad [1/2]$$

$$= \frac{22}{7} \times 7 \times 7 \times 25 = 3850 \text{ cm}^3 \quad [1/2]$$

$$\text{Space left} = 15625 - 3850 = 11775 \text{ cm}^3 \quad [1/2]$$

-0-0-0-

Buy the latest MTG CBSE books best prices at - <https://bit.ly/3QNnoOI>